



Submersible General Dewatering High Head Pumps

LH/LH-W GSZ-4



We reserve the right to change specifications and designs herein for improvement without prior notice.

TSURUMI
MANUFACTURING CO.,LTD.

Your Dealer



Extra endurable to high water pressure. Ideal for high-head pumping operations.

Oil Lifter (All models Pat. Pending)

This Oil Lifter was developed to improve quality and reliability of our submersible pump by enhancing sealing performance of the mechanical seal.

- * The Oil Lifter is a lubrication device for the mechanical seal that is the heart of the submersible pump.
- * The Oil Lifter stabilizes and enhances mechanical seal lubrication and cooling effect.
- * Offers stable sealing performances even if the oil level drops. Facilitates periodic inspection.

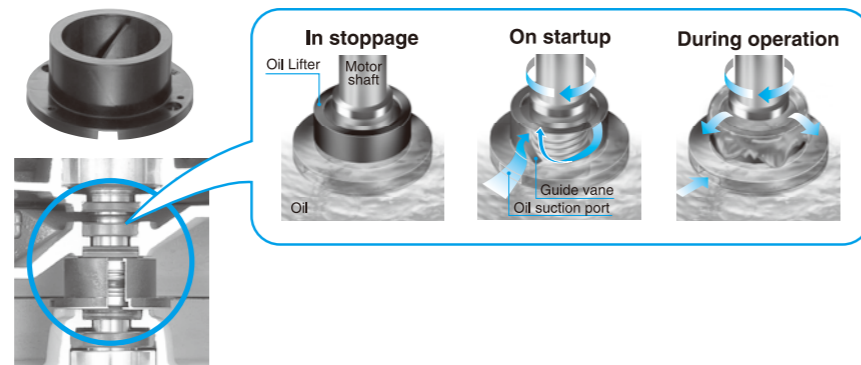

Seal pressure relief system (Except 3.0kW models)

This design features an independent pump casing built separately from the oil casing which incorporates the mechanical seal. An intermediate chamber, opened to the outside, is installed between the pump casing and the oil casing.

Thanks to this configuration, the mechanical seal is exposed to the static (submergence) pressure only without the pumping pressure operating on it. This prevents the mechanical seal from premature wear under the high-head pumping condition.

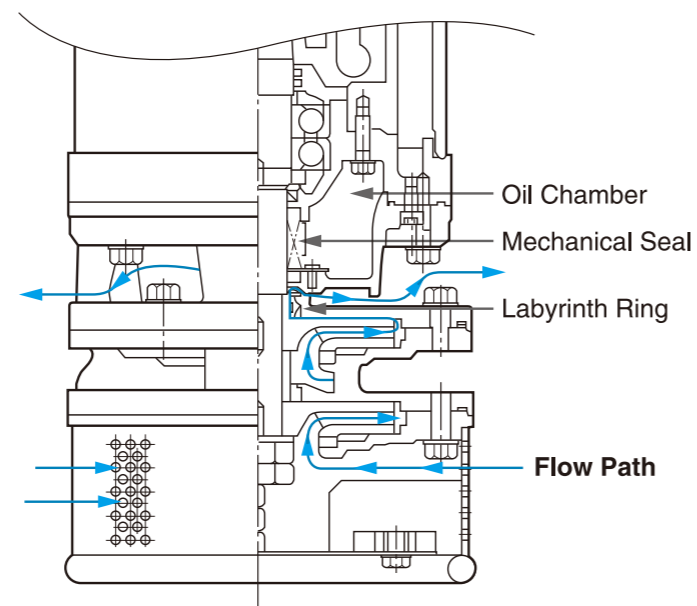

Performance by type

⊙ Standard equipment

Application	Submersible pumps		
	Deep well		Large capacity
Type	LH	LH-W	GSZ-4
Discharge bore (mm)	100~200	50~100	150~250
Output (kW)	15~110	3.0~30	37~75
Poles (p)	2	2	4
Center-flange specs	⊙	⊙ (Except 3.0kW)	
Cylindrical channel	⊙	⊙	
Dual impeller		⊙	
Forced motor cooling			⊙

Cylindrical channel (LH, LH-W)

The entirely cylindrical drive channel maintains the motor cooling efficiency adequately high even during operations at a low water level. Also, with the discharge port on its top (sketch), the pump can be installed in a narrow place.

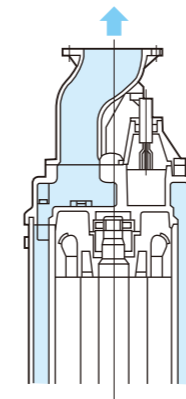

Dual impeller (LH-W)

The dual impeller (photo) remarkably increases the power of pumping up water from a great depth.

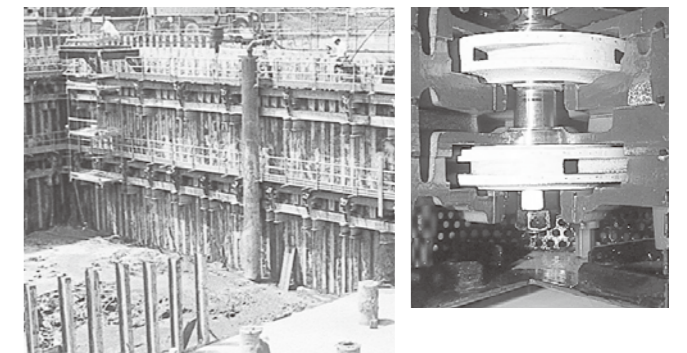

Center-flange construction (LH, LH-W)

Enables the pump to be lifted up/down without disconnecting it from piping and stably installed true to the center of gravity.



Forced motor cooling (GSZ-4)

Part of pumped fluid flows in between the outer cover and the motor housing before discharge and thus cools the motor on its way. This allows the pump to operate long and continuously even if it is exposed to the air.

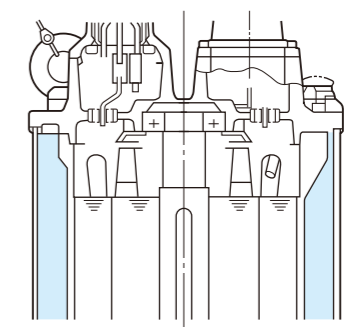



For deep-well pre-dewatering or high-head dewatering in civil engineering and construction works.



Performance Curves

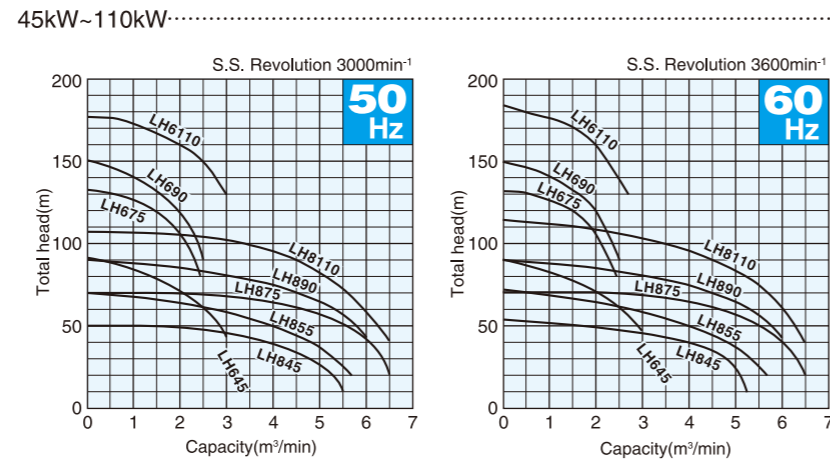
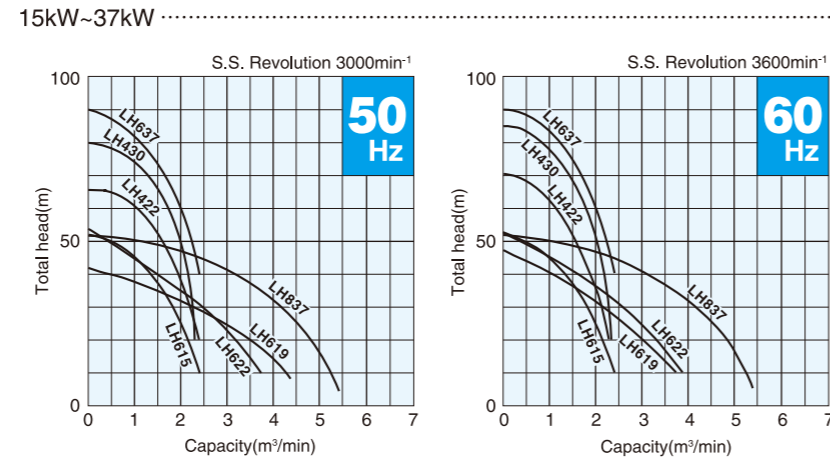

Major Standard Specifications

Item	Discharge size mm				
	100	150	200		
Pumping fluid	Type of fluid	Rain water, Ground water, Sand laden water			
	Liquid temperature	0~40°C			
Pump	Components	Impeller	Closed type		
		Shaft seal	Double mechanical seal, Water pressure endurance, 5kgf/cm ² (0.49MPa)		
		Bearing	Shielded ball bearing		
	Materials	Impeller	Chromium iron casting		
		Casing	Gray iron casting		
Motor	Type, poles	Dry-type submersible induction motor, 2 poles			
	Insulation	Class B (15~22kW), Class F (30~110kW)			
Motor	Phase / Voltage	Three-phase / 220V, 380V, 400V, 415V, 440V, 460V, 525V, 575V			
	Motor protector(built-in)	Circle thermal protector (15~22kW), Miniature protector (30kW or over)			
	Leakage sensor(built-in)	Electrode type (55kW or over)			
	Lubricant	Turbine oil (ISO VG32)			
Materials	Frame	Gray iron casting			
	Shaft	Stainless steel #420			
	Cable	Chloroprene sheath			
Discharge connection	JIS10K Flange	(15~55kW)			
	JIS20K Flange	(75kW or over)			

Standard Accessories

- Cabtyre cable 1 pc (2 pcs for 90 kW version or up)
- Discharge pipe 1 pc (on JIS10K flange specs; accompanying 422, 430, 615, 619, 622, 637, 645, 837, 845, 855, 875 and 8110 types)
- Discharge pipe 1 pc (on JIS20K flange specs; accompanying 675, 690 and 6110 types)
- Electrode-type leakage sensor 1 set (55 kW or over)
- Cathodic protection anodes

Optional Specifications

- Extended cable
- Special paint

Specifications 50/60Hz

Discharge Bore mm	Model	Motor Output kW	Phase	Total Head m	Capacity m ³ /min	Starting Method	Dry Weight kgs	Length of Cabtyre Cable m
100	LH422	22	Three-phase	60	1.0	D.O.L.	350	10
100	LH430	30	Three-phase	70/50	1.0/2.0	Star-Delta	355	10
150	LH615	15	Three-phase	35/25	1.5/2.0	D.O.L.	213	10
150	LH619	19	Three-phase	30	2.0	D.O.L.	350	10
150	LH622	22	Three-phase	35	2.0	D.O.L.	360	10
150	LH637	37	Three-phase	80/60	1.0/2.0	Star-Delta	495	10
150	LH645	45	Three-phase	80/60	1.4/2.5	Star-Delta	510	10
150	LH675	75	Three-phase	120	1.5	Star-Delta	850	10
150	LH690	90	Three-phase	120	2.0	Star-Delta	1100	20
150	LH6110	110	Three-phase	160	2.0	Star-Delta	1200	20
200	LH837	37	Three-phase	35	3.6	Star-Delta	495	10
200	LH845	45	Three-phase	35	4.5	Star-Delta	510	10
200	LH855	55	Three-phase	50	4.0	Star-Delta	810	10
200	LH875	75	Three-phase	60	4.5	Star-Delta	850	10
200	LH890	90	Three-phase	70	4.5	Star-Delta	1150	20
200	LH8110	110	Three-phase	90	4.5	Star-Delta	1250	20

*Dry weight of the pump excluding cable.

Dimensions

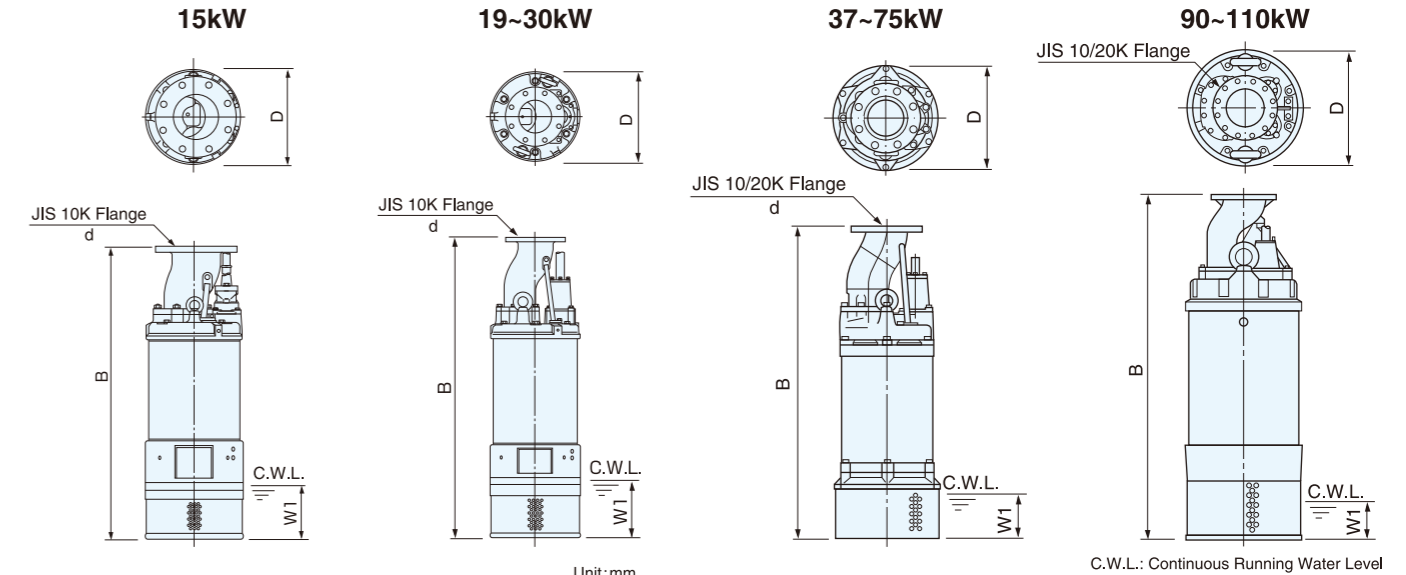

Model	d	B	D	W1
LH422	100	1352	420	250
LH430	100	1352	420	250
LH615	150	1014	330	185
LH619	150	1423	420	270
LH622	150	1423	420	270
LH637	150	1448	530	180
LH645	150	1448	530	180
LH675	150	1676	550	200
LH690	150	1787	592	200
LH6110	150	1787	592	200
LH837	200	1488	530	180
LH845	200	1488	530	180
LH855	200	1716	550	200
LH875	200	1716	550	200
LH890	200	1787	592	200
LH8110	200	1787	592	200

C.W.L.: Continuous Running Water Level

LH-W

The slim pumps that can be installed in a smaller pipe. Ideal for deep-well pre-dewatering. A dual impeller has greatly increased the pumping power to realize high-head specifications. (Model LH33.0 is a single impeller pump.)



LH23.0W

Major Standard Specifications

Item	Outlet Bore(mm)			
	50	80	100	
Pumping Liquid	Rain Water, Ground Water, Sand Laden Water			
Liquid Temperature	0~40°C			
Pump	Impeller	Closed Type		
	Shaft Seal	Double Mechanical Seal		
	Bearing	LH23.0W & LH33.0 - Pressure Endurance of 0.49Mpa (5kgf/cm ²) Other Models - Pressure Endurance of 0.98Mpa (10kgf/cm ²)		
	Impeller	Chromium Iron Casting		
	Material	LH23.0W & LH33.0 - Ductile Iron Casting Other Models - Gray Iron Casting		
Motor	Type, poles	Dry Type, Induction Motor, 2-pole		
	Class of Insulation	LH23.0W, LH33.0, LH430W - class F LH25.5W, LH311W, LH322W - class B		
	Phase / Voltage	3-phase, 220V, 380V, 400V, 415V, 440V, 460V, 525V, 575V		
	Motor Protector (Built-in)	Circle Thermal Protector (excl. LH430W) LH430W - Miniature Thermal Protector		
	Lubricant	Turbine Oil ISO VG32		
Material	Frame	Gray Iron Casting		
	Shaft	420 Stainless Steel		
	Cable	Chloroprene Rubber		
Discharge Connection	LH23.0W - Threaded Hose Connection (BSPT or NPT*)			
	LH25.5W, LH311W - JIS 10K Flange			
	LH322W, LH430W - JIS 20K Flange			

※When ordering, please specify BSPT or NPT.

Standard Accessories

- One 20m Long Power Cable
- Discharge Connection (Thread Connection or Flange)
- Galvanized Corrosion Protection Anodes (except 3kW models)

Optional Accessories

- Extended Cable
- Cathodic Protection Plates (3.0kW models only)
- Centered Discharge (JIS 10K) Flange (3.0kW models only)
- Special Paint

Performance Curves

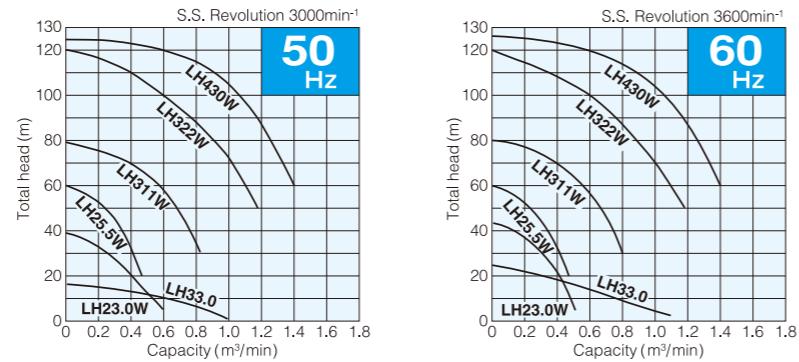

Specifications 50 / 60 Hz

Discharge Bore (mm)	Model	Motor Output (kW)	Phase	Total Head (m)	Capacity (m ³ /min.)	Starting Method	Dry Weight (kg)	Length of Cable (m)
50	LH23.0W	3	3-phase	32 / 35	0.2	DOL	46	20
	LH25.5W	5.5		45	0.3		80	
LH311W	11	65		0.5	130			
80	LH322W	22		100	0.6	304		
	LH430W	30		105	1.0	324	Star-Delta	
Single-Stage Model								
80	LH33.0	3.0	3-phase	12 / 15	0.5	DOL	41	20

※Dry weight of the pump excluding cable.

Dimensions

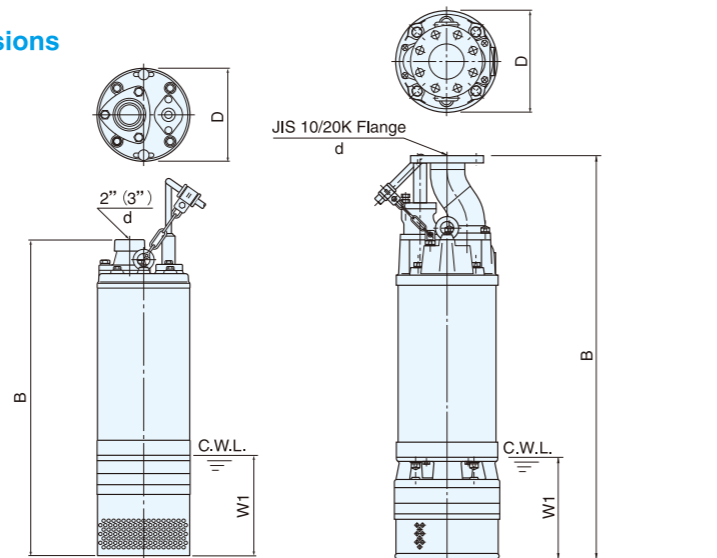

※() : LH33.0 Version

C.W.L.: Continuous Running Water Level

Model	d	B	D	W1
LH23.0W	50	630	185	200
LH25.5W	50	750	244	170
LH311W	80	1024	270	200
LH322W	80	1235	330	250
LH430W	100	1375	365	250
Single-Stage Model				
LH33.0	80	645	185	150

GSZ-4

Equipped with a 4-pole motor, the pumps in this series display their true virtues where a massive amount of water must be drained in a very short period of time.



Performance Curves

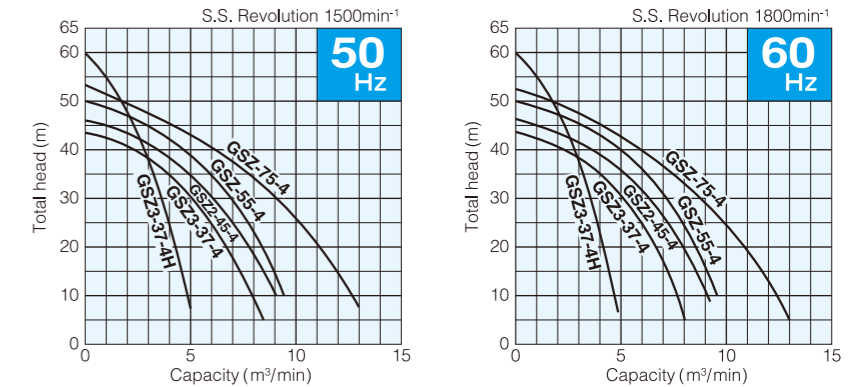

Specifications 50/60Hz

Discharge Bore mm	Model	Motor Output kW	Phase	Total Head m	Capacity m ³ /min	Starting Method	Dry Weight kgs	Length of Cable m
150	GSZ3-37-4H	37	Three-phase	45	2.0	Star-Delta	850	10
200	GSZ3-37-4	37	Three-phase	35	4.0	Star-Delta	850	10
200	GSZ2-45-4	45	Three-phase	35	5.0	Star-Delta	1100	10
250	GSZ-55-4	55	Three-phase	35	6.0	Star-Delta	1150	10
250	GSZ-75-4	75	Three-phase	40	6.0	Star-Delta	1200	10

※Dry weight of the pump excluding cable.

Dimensions

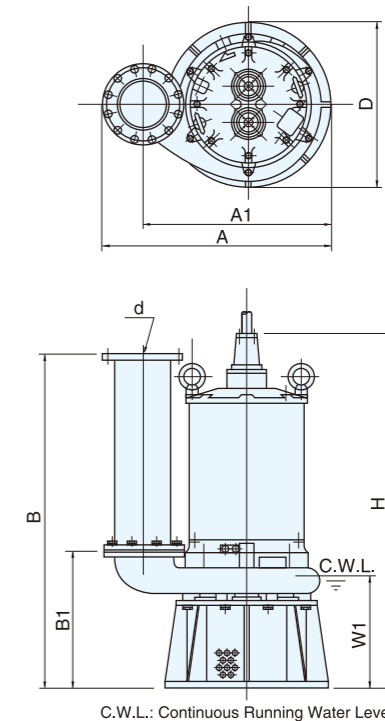

C.W.L.: Continuous Running Water Level

Model	d	A	A1	B	B1	D	H	W1
GSZ3-37-4H	150	900	760	1400	520	720	1501	440
GSZ3-37-4	200	915	750	1400	550	660	1531	480
GSZ2-45-4	200	915	750	1403	600	660	1641	460
GSZ-55-4	250	1050	850	1500	655	708	1733	510
GSZ-75-4	250	1050	850	1500	655	708	1733	510

Major Standard Specifications

Item	Discharge size mm			
	150	200	250	
Pumping fluid	Type of fluid	Rain water, Ground water, Sand laden water		
	Liquid temperature	0~40°C		
Pump	Components	Impeller	Closed type	
		Shaft seal	Double mechanical seal	
		Bearing	Shielded ball bearing	
	Materials	Impeller	Chromium iron casting	
		Casing	Gray iron casting	
Motor	Motor protector (built-in)	Miniature protector		
Motor	Type, poles	Dry-type submersible induction motor, 4 poles		
		Insulation		Class F (37kW) Class E (45~75kW)
	Phase / Voltage	Three-phase / 220V, 380V, 400V, 415V, 440V, 460V, 525V, 575V		
	Lubricant	Turbine oil (ISO VG32)		
	Materials	Frame	Gray iron casting	
Discharge connection	Shaft	Stainless steel #420		
	Cable	Chloroprene sheath		
Discharge connection	JIS10K Flange			

Standard Accessories

- Cabtyre cable 2 pc
- Discharge pipe (JIS10K Flange) 1pc

Optional Specifications

- Extended cable
- Special paint